

Cartridge Filters

- * Better pulse cleaning efficiency with vertical design
- * Equally spaced pleating with hotmelt increase rigidity
- * Larger filter surface ensures less maintenance costs
 - * Low pressure drop, less energy consumption
- * Long service life with using high quality filter media
 - * Double PU foam gaskets ensure airtight sealing
 - * Strong filter construction, self-supporting and easy mounted
- * Antistatic, flame retardant, cellulose synthetic fibers conductive media
 - * Vacuum resistant special design
 - * Nanofiber coated media for more efficient operation
 - * Other media options available (oleophobic, hydrophobic, washable)

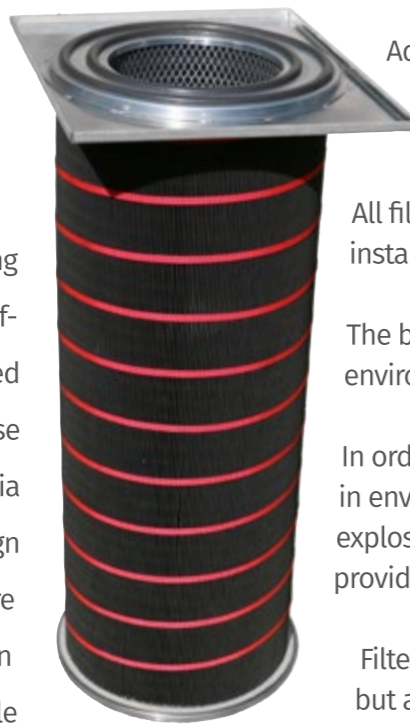

Provides solutions to safely remove dust and particulate pollution in wide range of industrial and commercial production environments. Ulpadust filters provides solutions to safely remove dust in wide range of end applications.

Advanced air filter materials according to type of contaminants meet the dust collector performance requirements.

All filters work in reverse-pulse cleaning installations for removing contaminants.

The best product for safer and cleaner work environment.

In order to comply with the protection in environment with high risk of dust explosions, filter with conductive media provides superior filtration performance.

Filters not only collect dust particles, but also work as an active component of protection system against the dust explosion.

Filter helps for preventing spark injection in the dust collector.

As an additional specification, nanofiber coated media is available against high amounts of submicron size contaminants which are in efficiency range of F7 to F9 according to EN779-2012.

Dust cake more easier release during reverse pulse cleaning than competitors.

Flame Retardant media available (F1 acc. to DIN 53438).

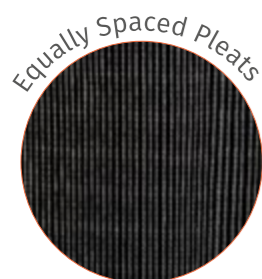

- (1) Open The Door
- (2) Side Shift The Inlet Door
- (3) Remove The Filters

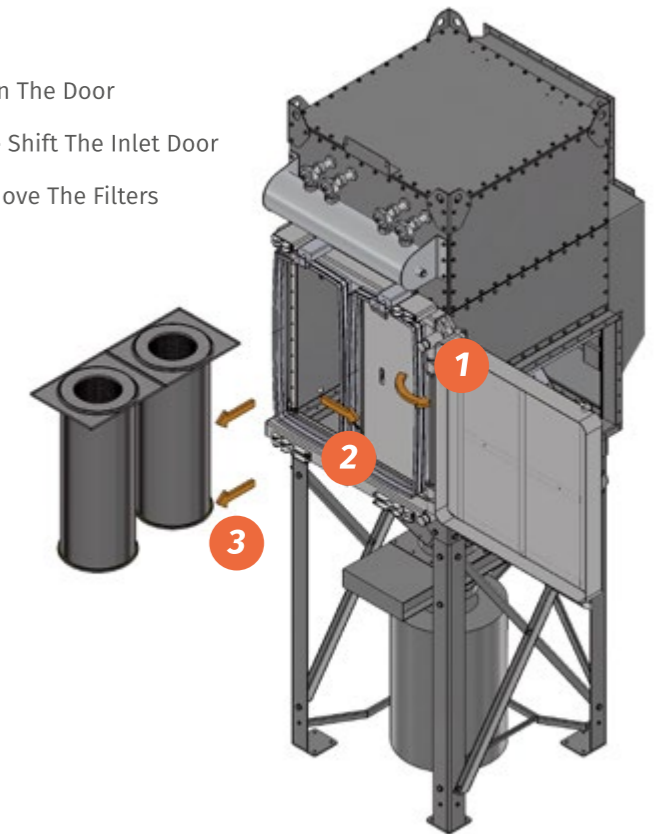

Easy Filter Change in few steps!

